

Recall of K50 hitch ball



QUALITY FOR LIFE

ALOIS KOBER GMBH
PO box 1165 · 89301 Günzburg · Germany

End customer

Your message/reference

Our reference

Direct dial

Fax

Date

Product recall of K50 hitch ball (AL-KO ref. 1275100)

Dear Sir or Madam,

According to our information, you are affected by this recall.

A potential product risk has been identified for the hitch ball mentioned above.

There is a risk of tensile separation due to a breakage of the hitch ball if it is used for a D-value higher than 17.2.

In concrete terms, this means:

Cars with a permissible gross weight of up to 3.5 tons are generally not affected. For vehicles with a maximum gross weight exceeding 3.5 tonnes, the D-value must be calculated (see page 4).

If the resulting D_{req} value is greater than 17.2, the hitch ball must be removed.

Important!

The **entered** weights/masses from the vehicle documents of the towing vehicle are decisive. Any smaller **actual** masses of the affected vehicle combination are **not relevant** for consideration.

Below are the "Instructions for handling product recalls".

Step 1: Identification of the K50 hitch (see page 3)

Step 2: Check if the D-value is in the inadmissible range (see page 3)

Step 3: Handling, remuneration and return of the used parts (see page 4)

Step 4: Certificate of removal (see page 5)

ALOIS KOBER GMBH
Ichenhauser Strasse 14
89359 Kötz
Germany
www.alko-tech.com

Tel. +49 8221 97-0 (Head Office)
Fax +49 8221 97-8449 (Head Office)
Fax +49 8221 97-8390 (Sales)
Fax +49 8221 97-8612 (Customer Service)

Deutsche Bank Augsburg
BIC: DEUTDEMM720
IBAN: DE22720700010500511100

Commercial Register Court:
Memmingen HRB 1683
VAT Reg. No. DE 811148849
Managing Directors:
Harald Hiller, Gero Neumeier,
Erwin Gentner

Recall of K50 hitch ball

AL-KO

QUALITY FOR LIFE

If your vehicle is affected by the recall based on the criteria described above, we ask you to contact us via the following options in order to coordinate the further procedure.

- Contact by telephone: 0800 255 6000 (free hotline within Germany)
- Contact by fax: +49 8221 / 97 – 8612
- Contact by e-mail: K50@alko-tech.com

Further contact options in Europe comprise the phone numbers and e-mail addresses of our European customer service offices as listed in the attachment.

Further information can be found on the specially set-up Internet pages:

- German: <http://www.alko-tech.com/de/rueckruf-kupplungskugel-k50>
- English: <http://www.alko-tech.com/de/recall-coupling-ball-k50>

If you are no longer the owner of the hitch ball/vehicle with the hitch ball, we ask you to inform us about the resale with details of the new owner (see page 6) or to pass this letter on to the new owner.

We apologize in advance for any inconvenience and thank you for your understanding and cooperation.

Kind regards,
ALOIS KOBER GMBH



Guido Kovermann
Senior Vice President
Customer Service

Calculate the identification of the K50 hitch and D-value

→ Appearance and dimensions:

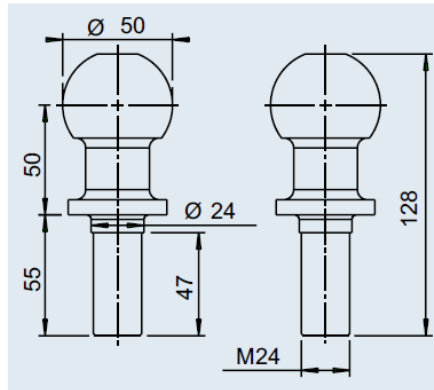

Ordering overview

Hitch balls Ø 50 - K 50	
Order no.	1 275 100
Perm. trailer load	3,500 kg
Nose load	120 kg
EG/ECE type approval	e1*94/20 *1763* /E1 55R-01 1763
Range of applications	Tractor linkage draw bar Important: Cannot be used in conjunction with an AKS
	1.0 kg
	- - units

→ Marking on the ball:



→ The required D-value according to Directive 94/20/EC or also according to the ECE-R 55 can be determined mathematically as follows:

$$D_{\text{erf}} = g \frac{T \cdot R}{T + R}$$

- D_{req}: Required D-value in kilonewtons (kN)
- T: Technically permissible gross weight of the towing vehicle in tonnes (t)
- R: Technically permissible gross weight of the trailer in tonnes (t)
- g: Gravitational acceleration (9.81 m/s²)

T and R can be found in the vehicle documents of the towing vehicle with the K50 hitch ball. (Certificate of Approval Part 1 / Vehicle registration document)

Handling, remuneration and return of the used parts

1. Get in touch with a workshop of your choice
2. Present this letter to the workshop
3. Arrange an appointment for testing and, if necessary, dismantling the K50 hitch
4. For disassembly of the K50 by the workshop, have the disassembly certificate (see page 5) filled in.
5. Be sure to have the old part handed over to you!
6. Ask the workshop to check whether the K50 is registered in its papers.
 - 6.1. The registration in the vehicle documents should be correct:
 - 6.1.1. Have the removal confirmed by the technical service
 - 6.1.2. Have the competent authority change the documents
 - 6.1.3. Keep the invoice
7. Send the invoices, old part and disassembly certificate to us for processing
 - 7.1. In order to send us the used parts, please request a procedure number (ARM 18-XXXX) from us in writing by e-mail (K50@alko-tech.com).
 - 7.1.1. Please provide us with your complete contact details and account details
 - 7.1.2. Your address and account data are mandatory for the reimbursement of costs!
 - 7.2. Please send the used part, the fully completed dismantling certificate (page 5) including your invoices to the following address:

Delivery address:

ALOIS KOBER GMBH
Recall of K50
Industriestraße 1
89359 Kötz

Invoice address:

ALOIS KOBER GMBH
Recall of K50
Ichenhauser Str. 14
89359 Kötz

8. The costs will only be reimbursed after receipt of the used part and the disassembly certificate.

Certificate of disassembly of the K50 hitch ball (AL-KO ref. 1275100)

1. Vehicle data

Chassis number (see vehicle documents) _____

Vehicle manufacturer and type _____

2. Customer (vehicle holder)

Last name, first name _____

Street _____

Postal code, city _____

Telephone _____

E-mail _____

3. Dealer / Workshop

Company name _____

Street _____

Postal code, City _____

Name of the employee
who has replaced the hitch _____

4. Details of the exchange

City, date

stamp + signature

Recall of K50 hitch ball



QUALITY FOR LIFE

Feedback in the event of resale

To notify us of the resale, please send us the following data per vehicle / customer:

Manufacturer and type of vehicle _____

Chassis number of the vehicle _____

Dealer:

Company _____

Name _____

Street _____

Postal code / City _____

Country _____

Telephone _____

Mail _____

Dealer:

Company _____

Name _____

Street _____

Postal code / city _____

Country _____

Telephone _____

Mail _____